

OWNER'S MANUAL

CRANE MACHINE LCM Version

TOY CHEST PIRATE CHEST

TICKET TIME HOT DIAMOND

CANDY CRANE

CANDY CRANE HOUSE

SWEETHEART CANDY CRANE

PRIZE TIME DELUXE

MY LITTLE DUCKS



SMART INDUSTRIES
www.smartind.com

MANUAL VERSION : F13E-R3-04
ISSUE DATE : 2017.01.03

CONTENTS

Section 1: Safety Notice

Section 2: Component

Section 3: About The Machine

Section 4: Game Introduction

Section 5: Wiring Diagram

Section 6: Troubleshooting

Section 7: Enclosure

Section 1:

Safety Notice

1 SAFETY NOTICE

- a. Please read carefully with enclosure of “Warranty”.
- b. Please read carefully with enclosure of “Maintenance”.
- c. Please check and maintain the machine regularly, DO NOT use any synthetic detergents to clean the machine.
- d. Places where the ground is sloping, uneven or there is strong vibration.
- e. Avoid direct sunlight machine placed in place in case the internal parts damaged.
- f. Avoid machine in high dust, high humidity, high temperature environment, so as to avoid damage to machine parts.
- g. Machine does not have waterproof, limited to indoor use, do not place water & beverages in the machine.
- h. DO NOT climbing or stand above the machine in any time, to avoid a threat to personal safety.
- i. Any casualties which caused by inappropriate behavior and dangerous acts, the Company shall not be responsible.
- j. This appliance is not for children and persons with reduced physical, sensory or mental capabilities or lack of experience and knowledge.
- k. After using this appliance should be cleaned to avoid the accumulation of grease and other residues.
- l. Children should be supervised to ensure that they do not play with the appliance.
- m. If the supply cord is damaged, it must be replaced by the manufacturer, its service agent or similarly qualified persons in order to avoid a hazard.

2 TRANSPORTATION AND MOVING

- a. Before moving the machine, make sure to unplug it from the mains.
- b. Turn off the power as notice before unplug from the mains, inappropriate handling will cause damage to the machine.

3 POWER NOTICE

- a. Before power connecting, verified the voltage is correct. 110V, 220V or 240V
- b. DO NOT touch the plug with damp hands to avoid electric shock.
- c. When installing the device, should ensure a smooth footing.

4 ORDER IN POWER ON

Plug in and turn on the power.

5 ORDER IN POWER OFF

Turn off the power and unplug

 Wait for 10 seconds to reboot

Section 2:

Component

List of Components

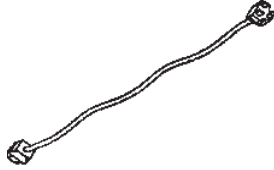
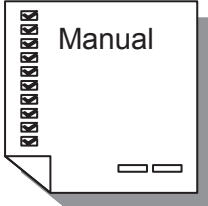
ITEM	DESCRIPTION	PICTURE
a. KEY	QT'Y : 5 REMARK : 2735 x 2 、 3123 x 2	
b. Power line	QT'Y : 1 REMARK : Plug form according area.	
c. Manual	QT'Y : 1 pc REMARK :	

Section 3:

About The Machine

About The Machine: Specifications

a. Voltage & Frequency	Voltage : 100V 、 110V 、 220V 、 240V (Refer to Specification Label) Frequency : 50/60HZ
b. User	1 person
c. Environment	Weather Protected Environment
d. Temperature	0°C~40°C
e. Humidity	10%~70%
f. Power Consumption	Maximum : 660W

Section 4:

Game Introduction

Game Introduction

1 How To Play

a. Game Instruction :

- (1) Insert coin(s)
- (2) Control the claw moving by joystick
- (3) Press CATCH button to catch
- (4) The claw moves to prize hole to release catching of prize

When the machine alarms error code, it will reboot automatically after alarming for 3 minutes. If the machine alarms again within 1 hour after rebooting, it will not reboot again. And it needs troubleshooting. But if the machine alarms again after 1 hour, the machine will reboot as it supposes to be after 3 minutes.

As the machine rebooting for error alarming has been disabled (the machine alarms again after 1 hour), it can be enabled by pressing SETTING button to enter setting page when turning on the machine.

2 System Setting

➤ Electronic Counter

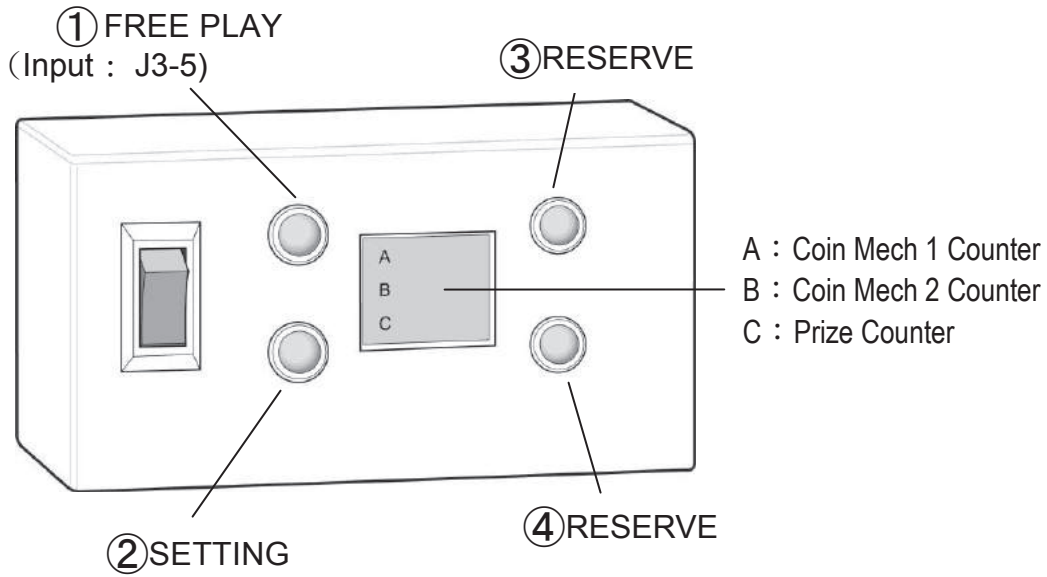

➤ Maintenance Tray

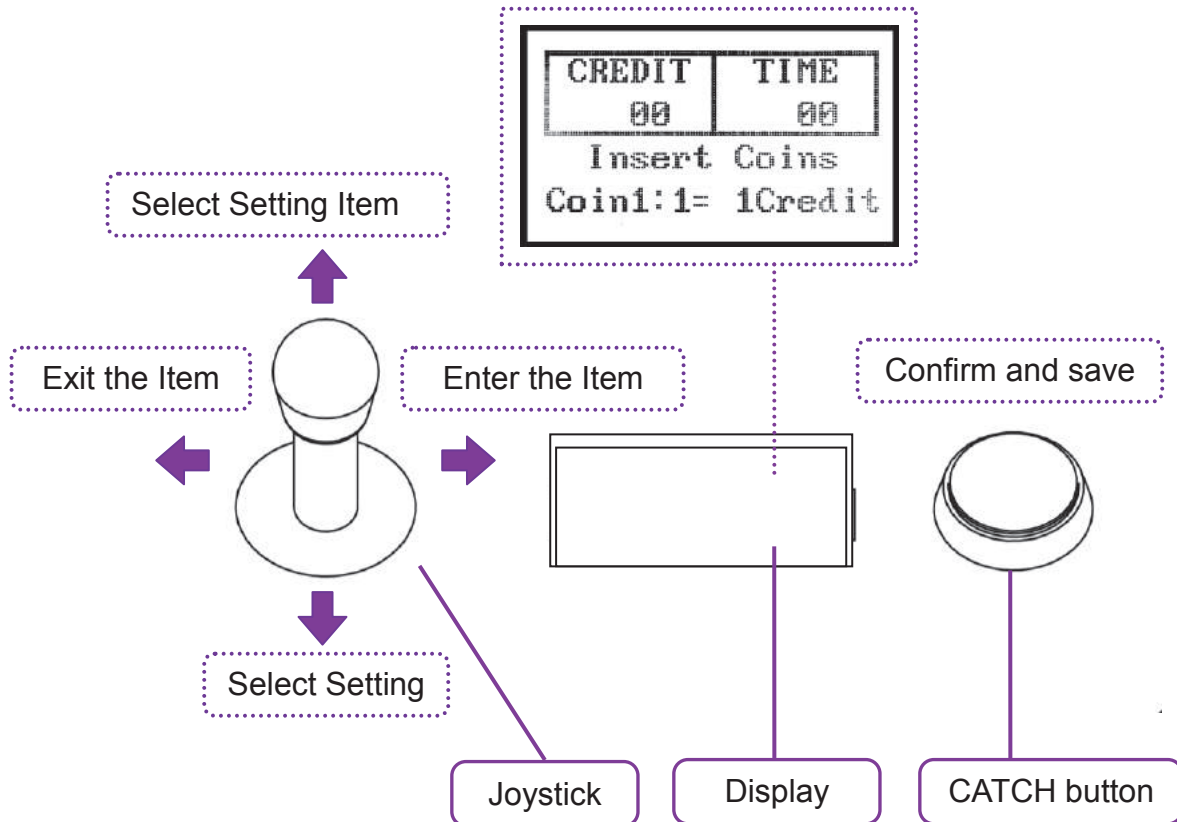

※ The arrangement above will be varied according to different machine version.



1. To Enter Setting Menu :

※ The range of values will be varied according to different machine specification.
Please refer to actual values on display.

- (1) When the machine is in stand-by mode, enter SETTING button to enter setting menu. Or keep pressing SETTING button and turn on the machine to enter setting menu.
- (2) 6 main setting items in setting menu :

>>A : Setting
>>B : Clamp Power (Claw Power)
>>C : Accounts
>>D : Play Mode
>>E : Motor Speed
>>F : Test
>>G : Default Value

Joystick: UP or DOWN - select items. RIGHT – enter the item. LEFT - Exit

2. >A : Setting :

>>A1 : Coin->Play
>>A2 : Game time
>>A3 : TSS (Trade Show Settings)
>>A4 : Attract Mu.(Music)
>>A5 : Clamp Catch
>>A6 : Coin Save
>>A7: Play T- Win (Play Till Win)
>>A8: Volume Adj
>>A9 : Clamp Start
>>A10 : Coin Disable/Enable
>>A11 : Clamp End-P (Position)

A1 : Coin->Play :

AA1 : Coin1 Set
AA2: Bill Accept. (Acceptor)
AA3: Credit > Play
AA4: Bonus
AA5 : Coin Display

Joystick : UP or DOWN - select items. RIGHT – enter the item. LEFT - Exit

>AA1 Coin1 Set :

AA1 : Coin1 Set
↑ : + ↓ : - ☀→Exit
1 C = 1 (1~10) Credits

Joystick [Up] / [Down]→ Adjust value
[CATCH] ☀→ Save & Exit

> AA 2: Bill Accept. :

AA 2: Bill Accept.
↑ :+ ↓ :- ☀→Exit
1 P = 1 (1~10) Credits

Joystick [Up] / [Down]→ Adjust value
[CATCH] ☀→ Save & Exit

AA 3: Credit > Play:

AA 3: Credit > Play
↑ : + ↓ : - ☀→Exit
1 (1~30) Credits =1 Play

Joystick [Up] / [Down]→ Adjust value
[CATCH] ☀→ Save & Exit

> AA 4 Bonus :

AA 4: Bonus
↑ : + ↓ : - ☀→Exit
1 (0~10) Plays +1 Play

COIN1 :

Joystick [Up] / [Down]→ Adjust value

[CATCH] ☀→ Save & Exit

> AA 5 Coin Display :

AA 5 : Coin Display
↑ ↓ :Change ☀ ->Exit
>> CREDIT / PLAY

Joystick [Up]/ [Down]→ Change setting

Display for : CREDIT OR PLAY.

[CATCH] ☀→ Save & Exit

A2 Game time : (example:30 seconds) ◦

A2 Game time		
↑ :+	↓ :-	☀→Exit
=	30	sec

Joystick [Up] / [Down]→ Adjust value

Range : 5~60 seconds

[CATCH] ☀→ Save & Exit

A3 : TSS : (Trade Show Settings)

The explanation below is for a setting of 100.

A3 : TSS		
↑ :+	↓ :-	→Next
=	100	
>>MODE: Random / Set		

Joystick [Up] / [Down]→ Adjust value

Joystick [Right] / [Left]→ Select

Range : 0~1000

MODE : Random / Set.

[CATCH] ☀→ Save & Exit

A4 : Attract Music :

(The explanation below is for demo music sounding per 5 minutes.)

A4 : Attract Mu.(Music)		
↑ :+	↓ :-	☀→Exit
->ON=	5	minutes

Joystick [Up] / [Down]→ Adjust value

Range : 1~30 minutes or disable ◦

[CATCH] ☀→ Save & Exit

A5 : Clamp Catch Position:

A5 : Clamp Catch
↑ ↓ : Change ☀ ->Exit
= At Air / At Bottom

Joystick [Up] / [Down] → Change setting

AT AIR – Available to catch in before claw reaches the bottom

AT BOTTOM—Only catch when claw reach the bottom

[CATCH] ☀ → Save & Exit

A6 : Coin Save :

A6 : Coin Save
↑ ↓ : Change ☀ ->Exit
=Save / Clear

Joystick [Up] / [Down] → Change setting

Save : To memory remaining credits when rebooting

Clear : Reset to 0 when rebooting

[CATCH] ☀ → Save & Exit

A7 : Play Till Win :

A7 : Play Till Win
↑ ↓ : Change ☀ ->Exit
=YES / NO

Joystick [Up] / [Down] → Change setting

YES : In win game, allow player to play all the time until winning

NO : Only allow player to play by credits even in win game.

[CATCH] ☀ → Save & Exit

A8 : Volume Adjustment:

A8 Volume Adj.		
↑ :+	↓ :-	☀→Exit
=	1~10	

Joystick [Up] / [Down]→ Adjust value

Range : 1~10

[CATCH] ☀→ Save & Exit

A9 : Clamp Start Position:

A9 : Clamp Start	
Start =	At Home / At center
Forward=	1.0 ~5.0 sec
Right=	1.0 ~5.0 sec

Joystick [Right] / [Left]→ Select

Joystick [Up] / [Down]→ Adjust value

The adjustment for seconds of “Forward” and “Right” is only available when it was set “At center”.

[CATCH] ☀→ Save & Exit

A10 Coin Disable/Enable :

A10 : Coin Dis/En	
↑ ↓ :Change	☀ ->Exit
When Game Start	
>> Coin Enable / Coin Disable	

Joystick [Up]/ [Down]→ Change setting

When Game Start to select : Coin Enable / Coin Disable.

[CATCH] ☀→ Save & Exit

A11 Clamp End-P (Position) :

A11 : Clamp End-P (Position)	
↑ ↓ :Change	☀ ->Exit
>> Clamp End-P (Position) Front /Behind	

Joystick [Up]/ [Down]→ Change setting

Clamp End-P(Position) Front / Behind.

[CATCH] ☀→ Save & Exit

B1 : Strong-V :

B1 : Strong-V
20.0V ~ 48.0V
↑ :+ ↓ :- ☀→Exit
= 48.0V

Joystick [Up]/ [Down]→ Change setting

Range: 20V~48V

[Press The CATCH Button] ☀→ Save & Exit

It will save the setting and exit automatically if operator doesn't change anything for 30 seconds.

B2 : Middle-V :

B2 : Middle-V
0.0V ~ 48.0V
↑ :+ ↓ :- ☀→Exit
= 20.0V

Joystick [Up]/ [Down]→ Change setting

Range: 0V~48V

[Press The CATCH Button] ☀→ Save & Exit

It will save the setting and exit automatically if operator doesn't change anything for 30 seconds.

B3 : Weak-V :

B3 : Weak-V
0.0V ~ 30.0V
↑ :+ ↓ :- ☀→Exit
= 10.0V

Joystick [Up]/ [Down]→ Change setting

Range:0V~30V

[Press The CATCH Button] ☀→ Save & Exit

It will save the setting and exit automatically if operator doesn't change anything for 30 seconds.

B4 : Mid-V Height :

B4 : Mid-V Height
1 (HI) ~ 10(LOW)
↑ :+ ↓ :- ☀→Exit
= 5

Joystick [Up] / [Down] → Change setting

Range:1~10 ,

1 : Highest ; 10 : Lowest

[Press The CATCH Button] ☀ → Save & Exit

1. > C : Accounts :

C : Accounts
C1>Bonus N. Bank
C2>Coin Play Cou.(Play Counter)
C3>Gift Out Cou. (Prize Counter)

C1 : C1:Bonus N. Bank :

(example : 0) ◦

C1 : C1 : Bonus N. Bank
Counter
= 0
"0"= push ☀-> 2 sec

Bonus N. Bank : the value increase 1 for every play by inserting coins, and will be reset after winning

Joystick → No use

Press [CATCH] once → Exit

Press [CATCH] once for 2 seconds → Reset value & Exit

C2 : Coin Play Counter :

(example : 31) ◦

C2 : Coin Play Cou.(counter)
Counter
= 31
"0"= push ☀-> 2 sec

Coin Play Counter : the value increase 1 for every play by inserting coins.

Joystick → No use

Press [CATCH] once → Exit

Press [CATCH] once for 2 seconds → Reset value & Exit

C3 : Gift Out counter : (Prize Counter)

(example : 17) ◦

C3 : Gift Out Cou. (prize counter)
Counter
= 17
“0”= push ☀-> 2 sec

Joystick → No use

Press [CATCH] once → Exit

Press [CATCH] once for 2 seconds → Reset value & Exit

2. >D : Play Mode:

>D: Play Mode
>>Business (Game Play Mode)
>>Free Play
>>Machine Test

Joystick [Up] / [Down] → Change setting

> Business : Disable free play mode.

> Free Play : Enable free play mode.

> Machine Test : To enter auto test mode. The mode is for QC purpose of manufacturer only.

[CATCH] ☀ → Save & Exit

3. >E : Motor Speed Adjustment:

>E : Motor Speed
E1>F&B Motor Sp. (Speed)
E2>L&R Motor Sp. (Speed)
E3>U&D Motor Sp. (Speed)
E4>All Speed 100%

E1> Forward & Backward

E2> Left & Right

E3> Up & Down

Joystick [Up] / [Down] → Select items

Joystick [Right] → Enter

Joystick [Left] → Exit

E1 : Forward & Backward Motor Speed Adjustment

E1>F&B Motor Sp. (Speed)
↑ :+ ↓ :- ☀→Test
=100%

Joystick [Up] / [Down] → Adjust value

Range : 30%~100%

30% : Slowest

100% : Fastest

[CATCH] → Save & Enter to test mode

Speed test mode :

E1>F&B Motor Sp. (Speed)
>>Joystick Test
=100% Test

Joystick [Up] / [Down] → To make motor moving forward or backward

[CATCH] ☀ → Exit

E2 : Left & Right Motor Speed Adjustment

E2>L&R Motor Sp. (Speed)
↑ :+ ↓ :- ☀→Test
=80%

Joystick [Up] / [Down] → Adjust value

Range: 30%~100%

30% : Slowest

100% : Fastest

[CATCH] → Save & Enter to test mode

Speed test mode :

E2>L&R Motor Sp. (Speed)
>>Joystick Test
=80% Test

Joystick [Right] / [Left] → To make motor moving left or right

[CATCH] ☀ → Exit

E3 : Up & Down Motor Speed Adjustment

E3>U&D Motor Sp. (Speed)
↑ :+ ↓ :- ☀→Test
=50%

Joystick [Up] / [Down] → Adjust value

Range: 30%~100%

30% : Slowest

100% : Fastest

[CATCH] → Save & Enter to test mode

Speed test mode :

E3>U&D Motor Sp. (Speed)
>>Joystick Test
=50% Test

Joystick [Up] / [Down] → To make claw rising or falling

[CATCH] ☀ → Exit

E4> E4>All Speed 100%

E4>All Speed 100%
>>No -->Exit
>>Yes -->Save

Joystick [Up] / [Down] → No/ Yes ◦

No : Refer to settings.

Yes : Speed of all motors are 100%

[CATCH] ☀ → Save & Exit

4. >F : Test :

F : Test
>>F1 : Gift Sensor
>>F2 : Coin Test

Joystick [Right] → Enter

Joystick [Left] → Exit

>F1 : Gift Sensor test (Prize Sensor Test)

Step 1 :

F1 Gift Sensor Test (Prize Sensor)
>>Sensor VR Adj.
LED=OFF
<< OK >>

Sensor Adjustment: Please adjust the sensor in this test

- (1) Check the LED on sensor. If it is on, make sure that no any obstruction remaining in prize chamber.
- (2) Adjust VR by screwdriver. Turn the VR clockwise to the end (lowest value) and the LED supposes to be off. If not, it is probably caused by sensor failure or improper black sticker inside prize chamber.
- (3) Adjust VR again. Turn it counterclockwise (increase value) until LED is on.
- (4) And turn it clockwise again until LED is off and then turn it clockwise a little more.
- (5) As the adjustment has been done, test sensitivity of the sensor by some items during the game.

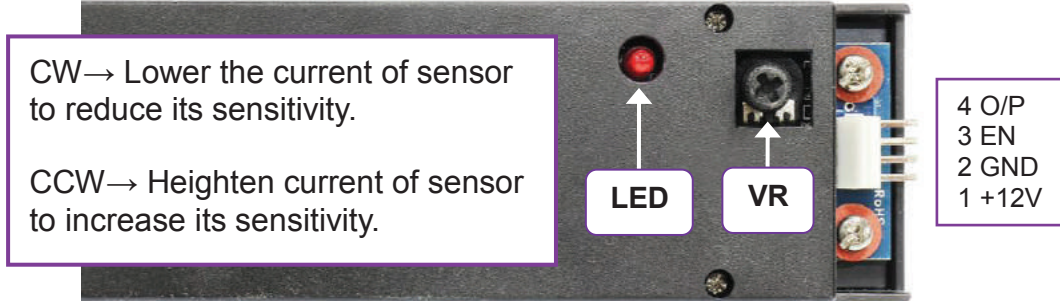

[CATCH] button : Enter to next item

Step 2 :

F1 Gift Sensor test
>>[CATCH]-->Exit
LED=ON
<< OK >>

- (1) Check LED is on or off. If it is off, it may be caused by loosing connector or sensor failure.
- (2) Step 1 and step 2 should be all ok.

>F2 : Coin Test

>F2 : Coin Test
~ Insert Coins ~
Coins=0

- (1) It counts once on "Counter" when inserting a coin. And it will not count on electronic counter.
- (2) Joystick [Left] or [CATCH] → Exit ◦

>G : Default Value

G : Default Value
>NO--> Exit
>YES-> Save & Exit

Joystick [Up] / [Down] → Change setting ◦

>> Select "YES" to make (AA5,A5,A6,A9) settings returning default value.

[Press The CATCH Button] ☀ → Save & Exit

**Default Value :

1. AA5 : Coin Display = PLAY .
2. A5 : Clamp Catch Position= At Bottom .
3. A6 : Coin Save= Clear .
4. A9 : Clamp Start Position = At center .

Section 5:

Wiring Diagram

LCD DIAGRAM

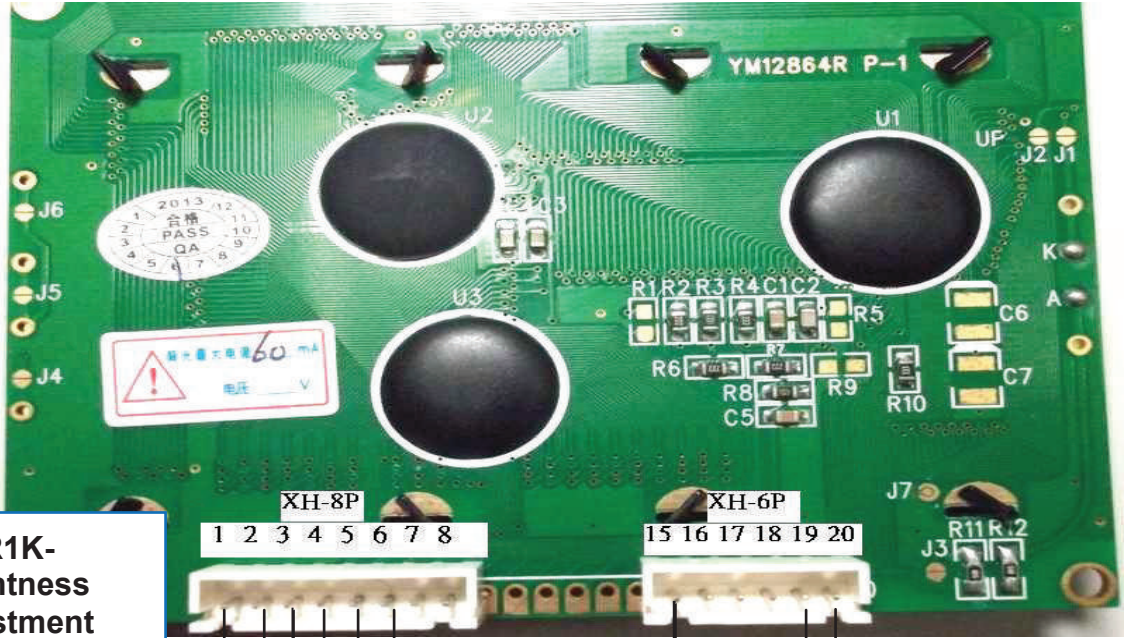

**VR1K-
Brightness
Adjustment**

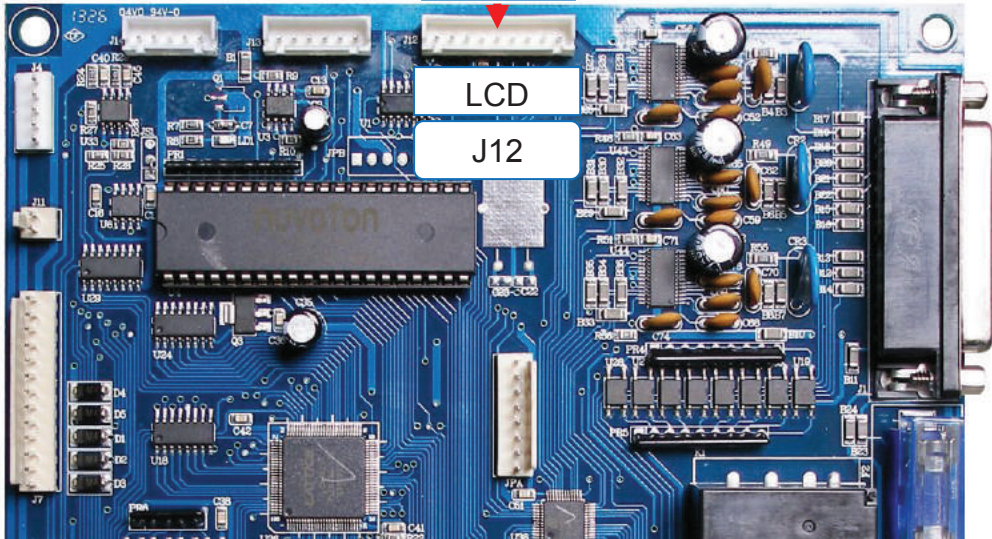
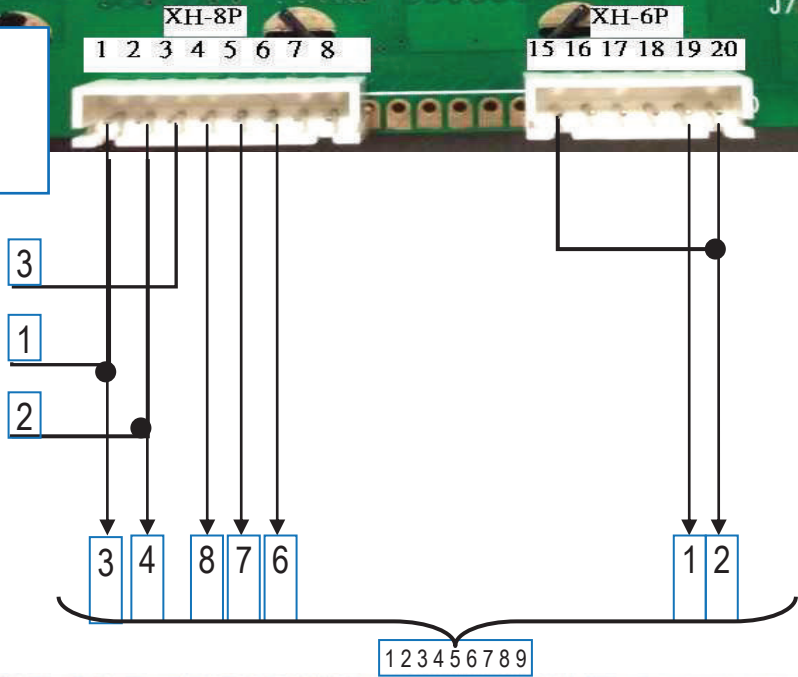
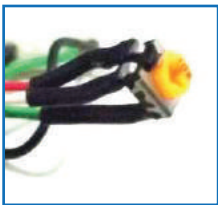
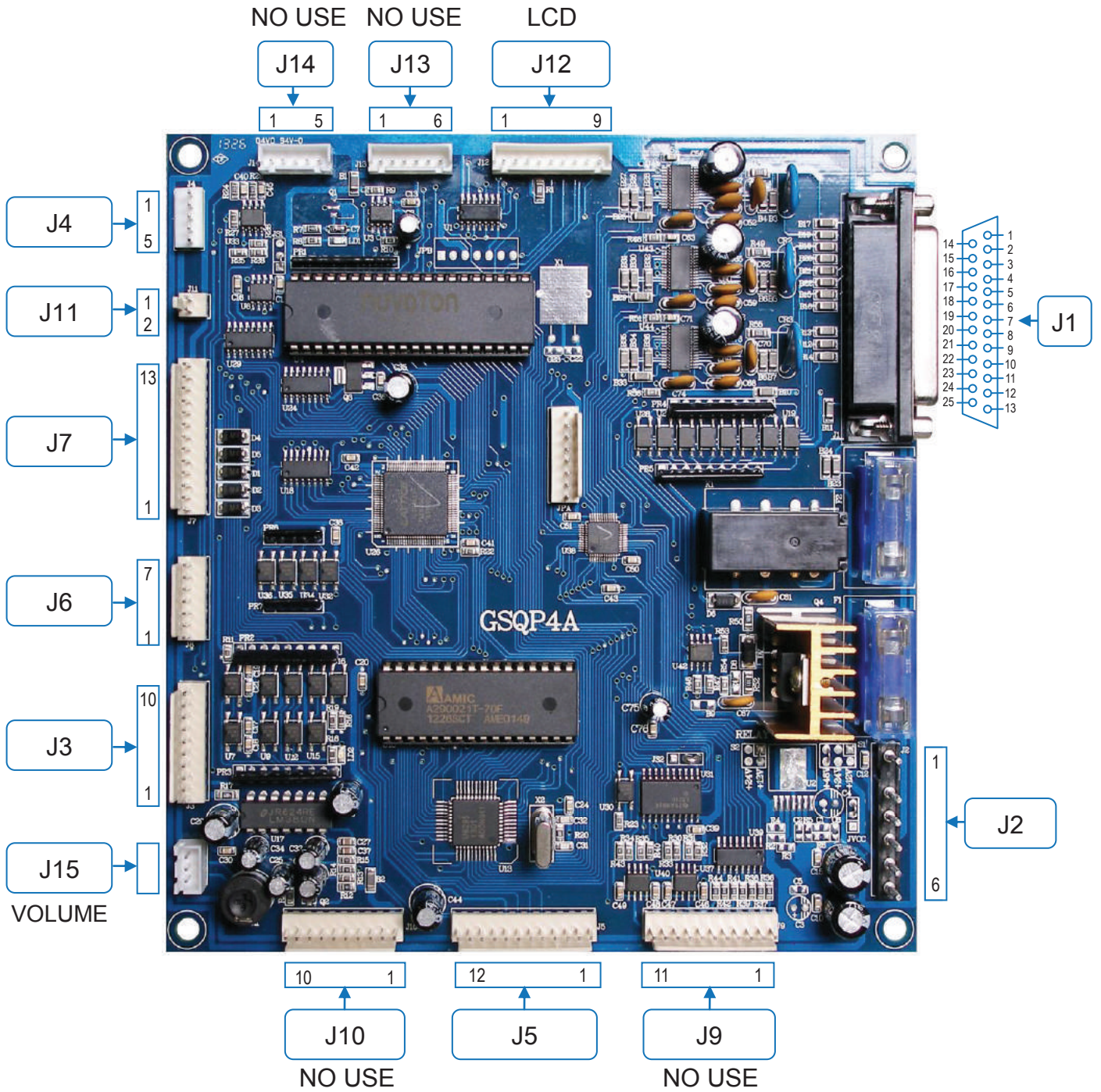

Diagram Of Main Board



J1 (GANTRY)		J2 (POWER SUPPLY)	J3 (SPEAKER & IINPUT)
1. & 14. FORWARD OR BACK MOTOR	11. NC	1. GND	1. +12V
2. & 15. LEFT OR RIGHT MOTOR	12. NC	2. VCC	2. GND
3. & 16. UP OR DOWN MOTOR	13. NC	3. +24V	3. SENSOR OUT
4. & 17. POWER SUPPLY FOR CLAW	18. GND	4. -48V	4. SENSOR IN 1
5. FRONT LIMIT SWITCH	19. GND	5. +48V	5. FREE PLAY
6. HOME LIMIT SWITCH	20. GND	6. +12V	6. TILT INPUT
7. NC	21. GND		7. GND
8. LEFT LIMIT SWITCH	22. NC		8. SETTING INPUT
9. TOP LIMIT SWITCH	23. NC		9. SPEAKER OUT
10. BOTTOM LIMIT SWITCH	24. NC		10. GND
	25. NC		
J4 (TILT SW)	J5 (COIN SELECTOR & METER)	J6 (JOYSTICK)	J7 (OUTPUT)
1. +12V	1. GND	1. CATCH BUTTON	1. LED LIGHT BAR 1
2. GND	2. GND	2. RESERVED	2. LED LIGHT BAR 2
3. NC	3. GND	3. LEFT	3. COIN2 METER
4. TILT SW IN	4. COIN SELECTOR 1 SIGNAL	4. RIGHT	4. BUTTON LAMP
5. NC	5. COIN SELECTOR 2 SIGNAL	5. BACK	5. +12V
	6. OUTPUT RESERVED	6. FORWARD	6. NC
	7. INPUT RESERVED	7. GND	7. NC
	8. COIN POWER (V+)		8. NC
	9. OUTPUT METER		9. NC
	10. INPUT METER 1		10. NC
	11. +12V		11. NC
	12. COIN2 /BILL ACCEPTOR		12. NC
			13. +5V
J11 (GND)	J12 (LCD)	J15 (VR)	
1. GND	3. ~9. LCD DISPLAY	1~3 VOLUME VR-10K	
2. GND			

Section 6:

Troubleshooting

Error Codes

NO.	ERROR ITEM	SOLUTION
01	COIN COUNTER 1 ERROR	(1) Check wiring (2) Replace counter
02	COIN COUNTER 2 ERROR	(1) Check wiring (2) Replace counter
03	PRIZE COUNTER	(1) Check wiring (2) Replace counter
04	COIN SELECTOR 1 ERROR	Check NC/NO SW on coin selector, it should be NO
05	COIN SELECTOR 2 ERROR	Check NC/NO SW on coin selector, it should be NO
06	PRIZE SENSOR ERROR	(1) Adjust sensor VR (2) Replace sensor
07	PCB DATA ERROR	Enter to setting menu to re-set all values
08	PCB MEMORY ERROR	Replace PCB
10	TICKET (CARD OR CAPSULE) OUTPUT ERROR	Refill tickets (cards or capsules)
11	MOTOR UP ERROR	(1) Check UP SW (2) Check fuse "F1" on PCB
12	MOTOR DOWN ERROR	(1) Check DOWN SW. (2) Check fuse "F1" on PCB
13	MOTOR LEFT ERROR	(1) Check LEFT SW. (2) Check fuse "F1" on PCB
14	MOTOR RIGHT ERROR	Check fuse "F1" on PCB
15	MOTOR FORWARD ERROR	(1) Check FORWARD SW. (2) Check fuse "F1" on PCB
16	MOTOR BACKWARD ERROR	(1) Check BACKWARD SW. (2) Check fuse "F1" on PCB

Section 7:

Enclosure

1 Warranty

Please be prepared to provide the following information for place a warranty request :

- (1) The Machine type or product number.
- (2) Serial Number of Game or Commercial Invoice of Sale.
- (3) A Detailed Description of the Equipment Fault Symptoms.

2 Maintenance

Items	Maintenance	Period	Notice
Interior clean	Use dry cloth with normal detergent to clean	Depend on machine situation	1.Do not use strong acid or corrosive detergent to clean 2. Do not use water to wash it directly to avoid any electronic damage
Exterior clean	Use dry cloth with normal detergent to clean	Depend on machine situation	1.Do not use strong acid or corrosive detergent to clean 2. Do not use water to wash it directly to avoid any electronic damage
Glass clean	Use dry cloth with normal detergent to clean	Depend on machine situation	1.Do not use strong acid or corrosive detergent to clean 2. Do not use water to wash it directly to avoid any electronic damage
Gantry clean	Use dry cloth to clean	Depend on machine situation	1.Do not use strong acid or corrosive detergent to clean 2. Do not use water to wash it directly to avoid any electronic damage
Check LEDs	Check LED Lights	monthly	Change LEDs as necessary
Check power cord	Check power cord	weekly	Do not touch power cord by hand directly to avoid electric shock